



MaxiDisc



GB
300, 400 cm

MaxiDisc

Type 300, 400 cm

Congratulations on the purchase of your new MaxiDisc. To ensure **safe operation** and to obtain optimal use of the machine, read the rules and instructions of the following operator's manual carefully before **operating the machine**.

©Copyright 2002, DAL-BO. All rights reserved.

Your MaxiDisc:

Type No.: _____ Serial No.: _____
Month of manufacture: _____ Net weight (kg): _____

For prompt service, always quote your machine serial number when making enquiries regarding spare parts or service. A comprehensive index of spare parts can be found in the back of this manual to give you an overview of MaxiDisc components and to facilitate ordering.

EU DECLARATION OF CONFORMITY

Maskinfabriken DAL-BO A/S
DK-7183 Randbøl

Hereby declare that the above-mentioned machine has been manufactured in compliance with the provision of the Council Directive on the approximation of the laws of the Member States relating to machinery 98/37/EC, which replaces Council Directive 89/392/EEC and amendments 91/368/EEC, 93/44/EEC and 93/68/ECC concerning the Essential Health and Safety Requirements for the design and manufacture of Machinery.

CE

This machine complies with the safety requirements stipulated by the European safety regulations.

Maskinfabriken DAL-BO A/S

Date: _____

Director Kaj Pedersen

Table of Contents

SAFETY	6
GENERAL	6
HYDRAULIC SYSTEM.....	7
HITCHING.....	7
MAINTENANCE AND REPAIRS	7
TRANSPORT.....	8
CORRECT USE	8
TECHNICAL DATA	9
HOW TO USE THIS MANUAL	10
DELIVERY	10
APPLICATION.....	11
HITCHING AND UNHITCHING.....	12
HITCHING.....	12
HYDRAULIC SYSTEM.....	12
UNHITCHING	12
ADJUSTMENTS AND SETTINGS	13
DEPTH.....	13
<i>Deeper soil penetration.....</i>	<i>13</i>
ANGLE	14
DISC SCRAPERS	14
SIDE DISCS	14
OPERATING AND DRIVING INSTRUCTIONS.....	15
ANGLE	15
TRAVEL SPEED.....	15
<i>Power requirements.....</i>	<i>15</i>
TROUBLESHOOTING	16
MAINTENANCE	17
LUBRICATION.....	17
HYDRAULIC SYSTEM.....	18
DISC HUBS.....	18
REPLACEMENTS AND REPAIRS	19
HYDRAULIC SYSTEM.....	19
<i>Replacing angle adjustment cylinder.....</i>	<i>19</i>
<i>Replacing angle adjustment seals.....</i>	<i>20</i>
REPLACING SHAFT, BEARINGS AND T-RINGS	21
REPLACING THE BEARING IN THE DISC HUB	21
SCRAPPING	23
HYDRAULIC SYSTEM DIAGRAM.....	24
SPARE PARTS.....	25

Safety



The safety alert symbol is used throughout this manual to identify important safety warning messages concerning your safety, the safety of other users or the functional safety of the implement. Observe all safety instructions and make them readily accessible to all users of the equipment.

General

- The operator must be thoroughly familiar with all safety precautions and operations of this equipment prior to using.
- The safety signs on the MaxiDisc contain important instructions concerning your safety, the safety of those around you, and the correct operation of the machinery.
- Never allow anyone to ride on the implement during operation or transport.
- Never allow bystanders within the operating radius of the MaxiDisc when the implement is in operation. Operate the MaxiDisc only while seated in the driver's seat of the tractor.
- Ensure that wing section locks are engaged when the MaxiDisc is in a folded position. Secure control levers against unintentional operation.
- Before performing any adjustments, maintenance or repairs on the machinery, always unfold the MaxiDisc and lower the implement to the ground or secure in transport position, set the tractor brakes, turn off the engine and remove the ignition key.
- Remember to secure the drawbar stand and the lift arms (if applicable) with lynch pins.
- Operate the tractor and MaxiDisc only while seated in the driver's seat.
- Always drive according to conditions.
- Do not use the MaxiDisc unless all safety signs are installed. Replace defective safety signs immediately.

Hydraulic System

- Never allow bystanders within the operating radius of the MaxiDisc when the hydraulic system is activated to avoid the danger of an individual being crushed or pinched between the equipment.
- Before performing maintenance or repairs on the hydraulic system, lower the implement to the ground, relieve pressure in the system, turn off the engine and remove the ignition key.
- Clean the hydraulic fittings thoroughly before connection. Ensure that the pressure is relieved in the hydraulic system before connecting the hydraulic hoses to the tractor's hydraulic services.
- After making repairs to the hydraulic system, thoroughly bleed air out of the system.
- Regularly check hydraulic hoses for defects such as cracks, bends, chafing or leaks.
- Avoid spilling oil on the ground. In case of spills, collect the oil and dispose of it properly.
- In case skin should come in contact with hydraulic oil or grease or in case clothing should become stained with oil, remove the stained clothes immediately and wash the affected skin areas thoroughly. Oil and grease are harmful to the skin.
- Escaping hydraulic oil under high pressure can penetrate the skin and cause severe injury. If an accident occurs, see a doctor immediately.

Hitching

- An individual is in danger of being crushed during the hitching process. Never place yourself or anyone else between the tractor and the MaxiDisc, or between parts that must be attached or connected.

Maintenance and Repairs

- Before servicing or making adjustments to the machine, securely block or unfold the machine, engage the tractor and machine brakes, stop the engine and remove the keys.
- Tighten all nuts, bolts hydraulic fittings or any other fastened assemblies after a few hours' use. Check often to make sure that they remain thoroughly tightened. Inspect all pins, screws and bolts for wear or damage and make sure that all are securely in place to avoid any possible damage or breakdown of the machine.

- Dispose of oil, grease and filters according to applicable environmental regulations.

Transport

- All safety and warning signs and devices required by law must be displayed, mounted and tested for public road use. The driver is responsible for the correct use of lights and markings in compliance with the present Traffic Act and Highway Code of the local traffic legislation.
- It is the responsibility of the driver to consult with local traffic authorities in order to ensure that the size, weight and load of the machinery may be transported on public roads.
- When towing the implement, the total weight of the tractor and the maximum allowed axle load must not be exceeded. The weight on the front axle must not be less than 20 percent of the total mass of the tractor. If it is less than 20 percent, extra weight must be added to the front of the tractor.

Correct Use

- Correct use of the MaxiDisc includes adherence to the instructions of the manufacturer concerning operation, maintenance and repair, as well as the use of genuine factory replacement parts.
- Do not allow anyone to operate, maintain or repair the MaxiDisc unless they are familiar with the implement and they are thoroughly aware of the possible hazards.
- The manufacturer does not accept any liability for injury or warranty if the equipment has been altered in any way without prior authorization from the manufacturer or if the injury is a result of incorrect use of the implement. The user accepts complete responsibility in these cases.
- Never load extra weight onto the MaxiDisc.

Technical Data

MaxiDisc

Size (cm)	300	400
HP (recommended)	100	140
Gross weight kg:	1720	2290
T-rings	Yes	Yes

How to Use This Manual

If the order of points described under the main subject areas of the manual seems confusing or illogical, refer to the Table of Contents where all subject headings can be found.

The main points of the operator's manual are placed into five main categories:

- Safety
- Set-up and Operation
- Options
- Maintenance
- Repairs

The following safety alert symbols are used throughout this manual to indicate:



Points that are extremely important for the function and life of the machinery.



Points that involve safety.

Delivery

MaxiDisc is delivered fully assembled on a flatbed lorry.

If the MaxiDisc needs to be lifted, it is recommended that you lift with straps around the middle section, raising the machine so that it hangs in balance.

Application

MaxiDisc represents a whole new generation of lift-mounted disc harrows providing the ultimate in compactness.

The MaxiDisc is specially designed for work in the uppermost soil layer where residue management is concentrated. The MaxiDisc effectively performs full cutting penetration of the field and uniform mixing and blending of plant residue and soil microorganisms in just one pass. The final element of the soil management system is a packer roller, ensuring moisture conservation and promoting an optimal microclimate for the organisms in the soil.

Fig. 1



Hitching and Unhitching

Hitching

Attach the lift arms first and then the top link. Adjust the top link so that the frame is horizontal.

Fig. 2



- Remember to secure with lynch pins.

Hydraulic System

The MaxiDisc requires one double-acting hydraulic outlet.

Table 1. Hose markings

Cylinder	Colour	Outlet	Function
Angling	Green	Double-acting	Angling discs



- Check the hydraulic hoses for kinks or pinches.

Unhitching

Position the MaxiDisc on solid, even ground. Disconnect the lift arms and the top link.



Remember to relieve the pressure in the hydraulic system before disconnecting the hoses.

Adjustments and Settings

The MaxiDisc is preset in the factory, but it will always be necessary to make some fine adjustments before use. Numerous adjustment possibilities make your MaxiDisc more versatile and allow you to obtain optimum performance from the implement.

Depth

The operating depth is controlled by the rear T-ring roller.

Adjust the depth of the discs by moving the pins in the brackets. The topmost pin (A) determines the depth, while the pin at the bottom (B) is the supporting pin that bears the roller when the implement is raised.

Fig. 3

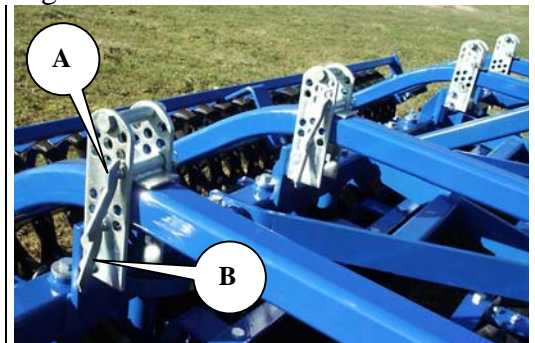

It might be necessary to readjust the top link after changing the depth. The frame must always be horizontal.

Deeper soil penetration

To increase the penetration depth, raise the implement. Next, remove the pin (A) from the bracket and insert it one hole higher. Lower the MaxiDisc and move the pin on the bottom (B) correspondingly up, so that the support is as close to the arm as possible.

If the MaxiDisc has been operating at a deep setting, it might be necessary to run the discs slightly in the soil (or to support the roller) to put pressure on the roller. The pin (B) can then easily be inserted into the hole that is closest to the arm.

Angle

The discs can be hydraulically adjusted from 0 to 20 degrees. With hydraulic adjustment, all discs are adjusted at the same time.

The angle of the front row and the back row of discs can be adjusted individually with the turnbuckle (A). It is generally recommended that you set the row in the back slightly more aggressive than the row in the front to prevent the machine from pulling unevenly.

Fig. 4



Disc scrapers

Adjust the disc scrapers, allowing only 3 to 5 mm of space between each disc and scraper.

Fig. 5



Side discs

A disc mounted on the outside edge of the MaxiDisc limits the amount of soil being cast out by the disc in the very front. Adjust the side disc vertically by using the pin (A) according to the working depth of the MaxiDisc. The disc can also be moved in a horizontal direction by loosening the mounting bolt.

Fig. 6

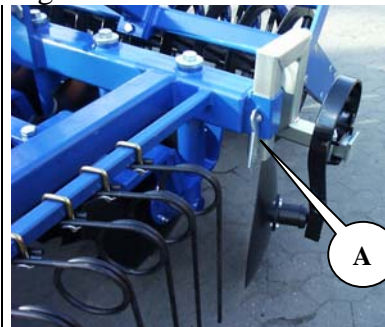

Operating and Driving Instructions

Proper operation is essential for optimum performance of your MaxiDisc. Proper operation concerns both the carrying out of tillage operations in the field as well as the following of safety precautions. Make sure that you have a thorough understanding of all safety precautions.

Best results will be achieved by driving slightly diagonally to the sowing direction. Also, you should drive as closely as possible to the previous pass to minimise the distance between the rows.

Angle

The angle of the discs can be continuously adjusted hydraulically during operation, enabling the operator to obtain the optimal setting according to field conditions. If there are many patches of plant residue on the field, the angle can quickly be reduced to avoid blockage. The angle can also be reduced if the need for pulling force becomes too great.

Travel Speed

A working speed between 8-12 km/hour is recommended, but always drive according to conditions.

When the travel speed is increased, wear on the implement is increased, especially under dry soil conditions. Damage to the discs and T-rings may also result from driving too fast under unfavourable conditions.

Power requirements

Power requirements change according to soil type, terrain and travel speed.

Table 2, **Guidelines for power requirements in HP**

Working width	300 cm	400 cm
Power requirements hp	90 - 100	120 - 140

Troubleshooting

Problem	Cause	Action
Soil is thrown too far out to the sides, creating a ridge.	<ul style="list-style-type: none"> • MaxiDisc is not horizontal. 	<ul style="list-style-type: none"> • Adjust the top link until the main frame is horizontal.
	<ul style="list-style-type: none"> • The travel speed is too fast. 	<ul style="list-style-type: none"> • Drive slower.
	<ul style="list-style-type: none"> • The angle is too aggressive. 	<ul style="list-style-type: none"> • Adjust the angle.
	<ul style="list-style-type: none"> • Driving too closely or too far away from the previous pass. 	<ul style="list-style-type: none"> • Driving too closely or too far away from the last pass.
A depression in the soil or furrow develops between passes.	<ul style="list-style-type: none"> • Driving too closely or too far away from the previous pass. 	<ul style="list-style-type: none"> • Driving too closely or too far away from the last pass.
	<ul style="list-style-type: none"> • The rear row of discs is too aggressive or too passive. 	<ul style="list-style-type: none"> • Set the rear row of discs less or more aggressively.

Maintenance

Proper maintenance ensures a long life for the MaxiDisc and also optimum performance from the implement. To facilitate maintenance, grease fittings have been mounted on those locations where wear on the equipment is the greatest.



Tighten all nuts, bolts, hydraulic fittings or any other fastened assemblies after the first workday. Inspect all pins and bolts for wear or damage and make sure that all are securely in place to avoid any possible damage or breakdown of the machine. Check for leaks in the hydraulic system.



Before servicing the machine, always lower the implement, engage the tractor brakes, stop the engine and remove the ignition key to avoid unintentional operation and personal injury.

Lubrication

Fig. 7

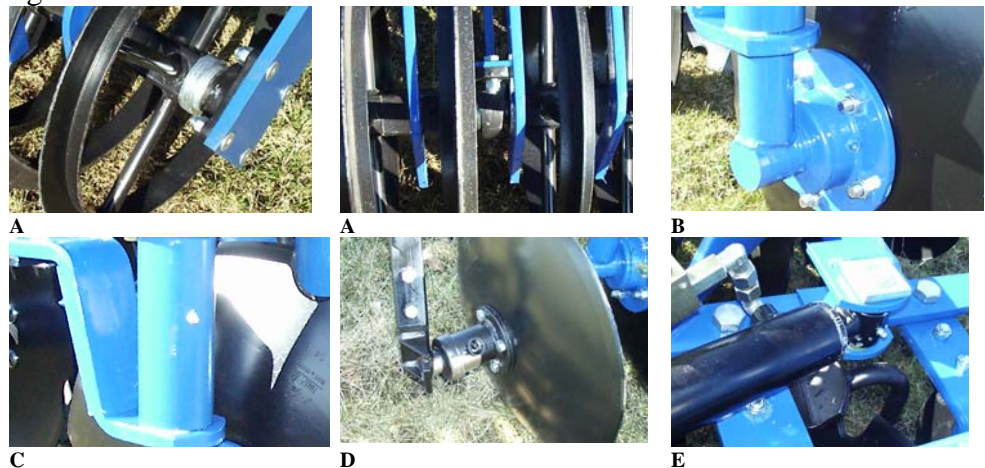

Lubrication points	Number of fittings	Lubrication interval (hours)	Photo
T-ring bearings	3/4	50	A
Hub	24/34	50	B
Disc pipe	24/34	8	C
Side discs	1	50	D
Angle adjustment cylinder	2	25	E



Lubricate all lubrication points at least once a year.

Hydraulic System



Inspect all hydraulic hoses for chafing or leaks. Check hoses for pinching.



To avoid rust, any projecting piston rods should be coated with oil or grease if the MaxiDisc is to be parked for a long period of time. Remember to remove the oil or grease prior to operation.

Disc hubs

Tighten the disc hubs once a year or as needed.

1. Screw off the cap.
2. Remove the split cotter pin from the nut.
3. Tighten the nut $\frac{1}{4}$ turn or until there is no play in the hub.

Fig. 8



Replacements and Repairs



Safety is important in connection with **all** repair work on the MaxiDisc. The following safety precautions and the precautions listed in the beginning of this manual must be observed.



Before performing any adjustments, maintenance or repairs on the machinery, always unfold the MaxiDisc and lower the implement to the ground or secure in transport position, set the tractor brakes, turn off the engine and remove the ignition key to avoid unintentional operation.



Pay careful attention to safety when performing repair work on the hydraulic system. Remove hydraulic pressure prior to doing any maintenance.



After making repairs to the hydraulic system, always bleed air out of the system before operating the MaxiDisc again to avoid any possible personal injury or mechanical breakdown or damage.

Hydraulic System

Replacing angle adjustment cylinder

Lower the MaxiDisc to the ground and relieve the pressure in the hydraulic system.

- 1 Disconnect the hoses.
- 2 Remove the pins.
- 3 The cylinder is now free. Install a new cylinder. Follow the instructions in reverse order.

Fig. 9



After installing the new cylinder, always bleed air out of the system and check for leaks.

Replacing angle adjustment seals

Fig. 10

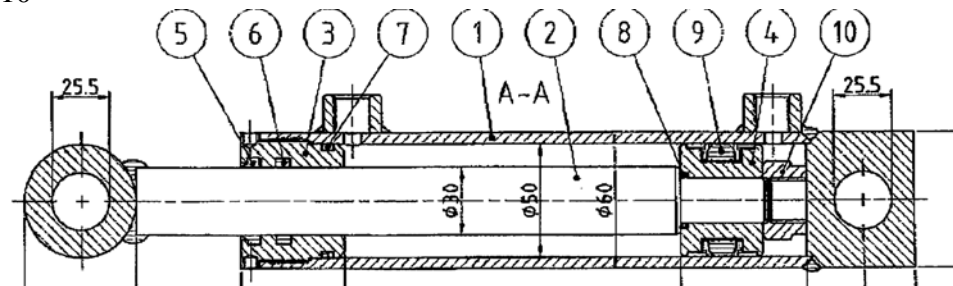
Cylinder 50/30-150

- 1 Empty the oil from the cylinder by carefully moving the cylinder back and forth.
- 2 Move the piston to the middle position. Unscrew the gland (pos. 3) from the cylinder casing (pos. 1). (A special tool is needed to remove the gland). If the gland is stuck, it may help to warm up the very front of the socket. When the gland has been unscrewed, pull the piston towards the gland. Pull the piston rod completely out of the cylinder casing (pos. 1).
- 3 Remove the self-locking nut (pos. 10) holding the sleeve (pos. 4).
- 4 Pull the sleeve (pos. 4) off the piston rod (pos. 2).
- 5 Pull the gland (pos. 3) off the piston rod (pos. 2).
- 6 Remove the seals from the gland and the sleeve (pos. 5+6+7+8+9).
- 7 Clean all parts thoroughly. Check for filings, shavings, burrs, and make sure that there is no rust around the scraper ring (pos. 5) in the gland. If rust is found, it must be removed.

Assembly

- 1 Assemble the new seals (pos. 5+6+7+8+9) into the gland and the sleeve.
- 2 Lubricate the screw threads on the gland (pos. 3) and the cylinder casing (pos. 1) with oil.
- 3 Mount the gland (pos. 3) onto the piston rod.
- 4 Mount the sleeve (pos. 4) and screw on the self-locking nut **with Loctite**. Make sure that the screw threads are completely clean and free from oil or other impurities before using Loctite. **Do not refill the oil for the first 12 hours after the application of Loctite.**
- 5 Lubricate the outermost seal of the sleeve that has contact with the cylinder casing and the inside of the cylinder casing, then guide the piston rod into the middle position of the casing.
- 6 Screw the gland onto the casing and tighten.

Replacing shaft, bearings and T-rings

Lower the MaxiDisc to the ground. Securely support and block the roller if necessary.



Watch out for unintentional rolling movement when the bolts in the bearings have been removed.

- 1 Remove the bolts in the bearings.
- 2 Roll the shaft with the T-rings away from the frame.
- 3 Loosen the set screws in the bearings and slide the bearings off the shaft.
- 4 Pull the T-rings and the square tube of the shaft. Mount in reverse order.

Fig. 11



- Apply Loctite to the set screws in the bearings
- When mounting the shaft with bearings, make sure to position the bearings with the grease fittings facing towards the back, enabling easier access for lubrication and protecting them from stones.

Replacing the bearing in the disc hub



The MaxiDisc must be securely blocked and supported before pulling the disc leg out of the gang tube.

- 1 Remove bolts (A) and (B).
- 2 Pull the disc leg out of the gang tube.

Fig. 12

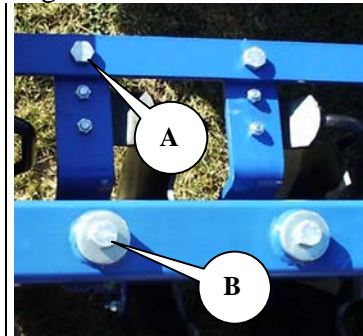

- 1 Remove the disc.
- 2 Unscrew the cap (21).
- 3 Take out the split cotter pin (20) holding the castle nut.
- 4 Remove the castle nut (19).
- 5 Pull off the hub (22) with a wheel puller.
- 6 Slide off the inner bearing.
- 7 Pull off the inner ring.

Fig. 13

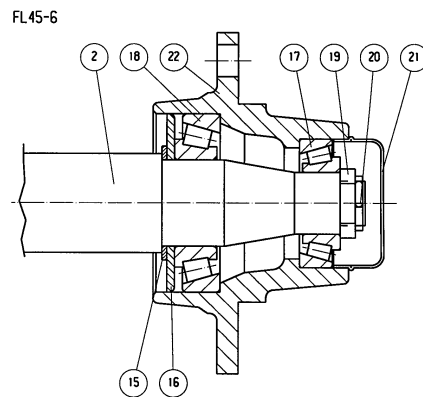

Clean the shaft and the cap.

- 1 To assemble, follow the instructions above in reverse order. Screw the castle nut onto the shaft while simultaneously turning the hub. Tighten the nut until it is difficult to turn the wheel. Now loosen the castle nut until the split pin lines up with a hole in both the shaft and the castle nut (if the wheel still drags when it is turned, loosen the castle nut to the next hole in the nut).
- 2 Remember to replace the split cotter pin.
- 3 Fill the cap $\frac{3}{4}$ with grease and reinstall.

Scrapping



Relieve the pressure in the hydraulic system.



When dismantling/mounting components, always pay attention to the weight of the part that you are about to handle. It is **important** to support or secure the part so that it cannot fall.

Dismount all hydraulic hoses and cylinders and empty the oil. To avoid pollution of the ground and the surrounding area, collect as much oil as possible. Dispose of the oil and the hoses properly.

All iron used in the machine is recyclable.

Hydraulic System Diagram

Hydraulic diagram for angle adjustment

Fig. 14

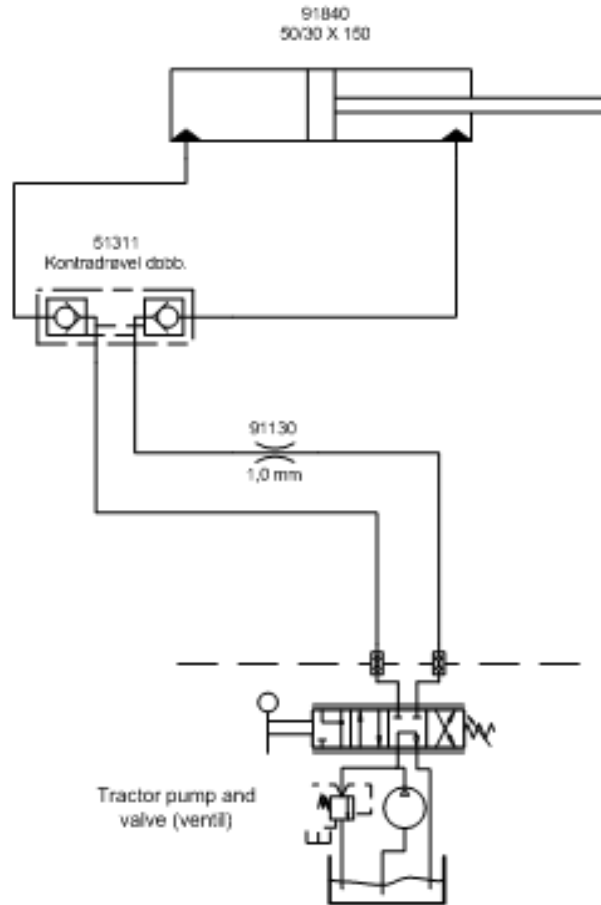



Spare Parts